

TIS-1250

SuperCap UPS



Introduction

This document describes the purpose, design, use, and performance of the Turn Island Systems TIS-1250 SuperCap Uninterruptible Power Supply.

Table of Contents

Introduction	1
Purpose.....	2
Specifications.....	2
Design.....	3
Use.....	3
Performance.....	4

Purpose

The TIS-1250 provides momentary power, allowing a connected computer to operate during brief power interruptions.

This SuperCap UPS is based on the work and design of Clint Turner (KA7OEI), with slight circuit modifications and mechanical design by Turn Island Systems. Please see Clint's discussion of the problem, and this solution:

<https://ka7oei.blogspot.com/2025/01/a-short-term-ups-for-mini-nuc-type-pcs.html>

The small NUC computers such as the Beelink series are incredibly capable and have become the computer of choice for RX-888 SDR receiver installations that run ka9q-radio and wsprdaemon software. But providing these small computers with glitchless power can be a challenge. The small switching power supplies used with these computers do not store enough power to maintain their output voltage during brief power-outage events. Even the transient outages caused when a typical UPS switches into service have been seen to disrupt or reset the computer. The brief holdover provided by the TIS-1250 is sufficient to bridge the gap in power.

Obviously the TIS-1250 can be used in many other high-reliability applications, and can work with power supplies between 5 and 20 volts.

Specifications

Power (input and output) 2.5 mm x 5.5 mm, pin-positive.

20V, 10A maximum.

Jumper cable provided for TIS-1250 to Computer connection.

Dimensions: 85mm x 30mm x 95mm

Weight: 194 g / 6.5 oz.

Design

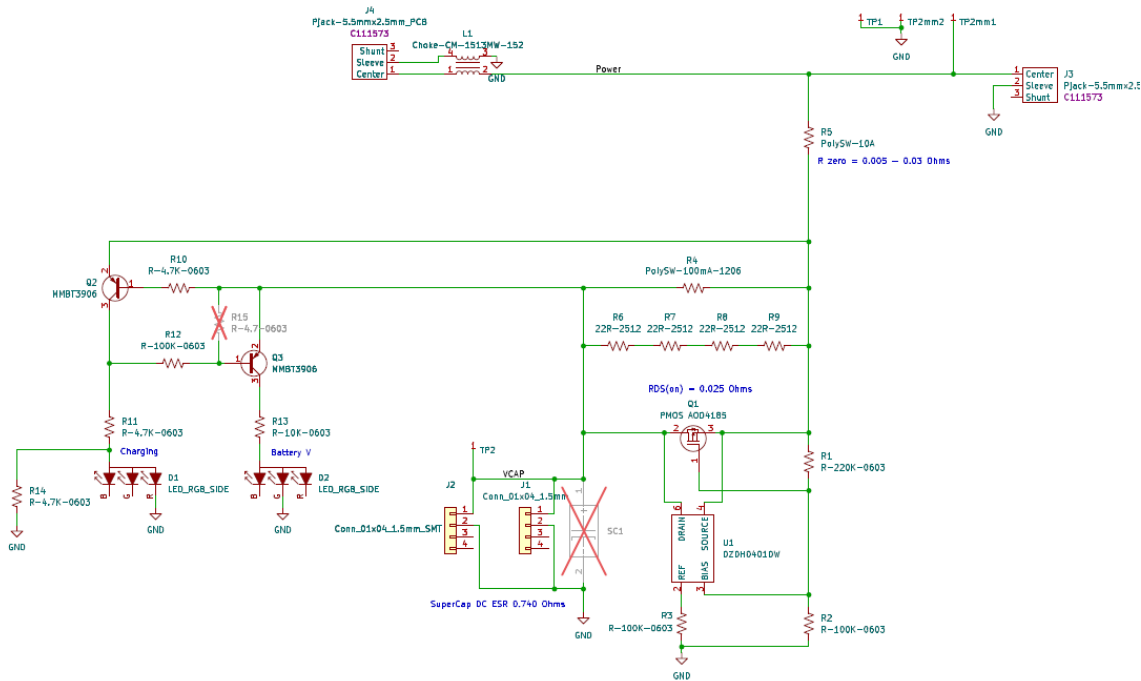

As described in the KA70EI blog, the key elements of the design are the SuperCapacitor SC1 (1.25 Farad), and the “ideal diode”, consisting of Q1 and U1. The ideal diode circuit provides a voltage drop that is much less than a regular Schottky diode, allowing the full capacity of the supercapacitor to be used.

The common-mode choke L1 provides some attenuation of common-mode currents that often exist when power supplies, computers, radios, and antennas share a ground connection.

Use

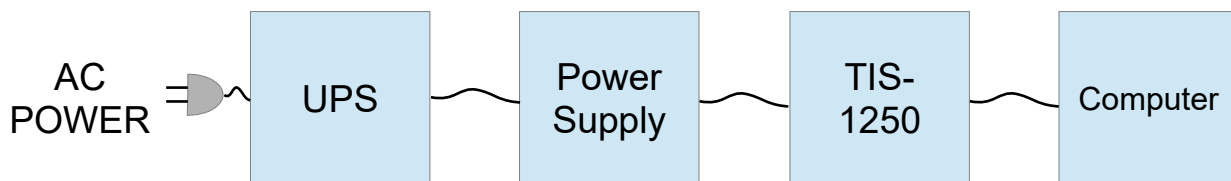

When power is first applied to the TIS-1250, the red “CHARGING” LED will illuminate. The supercap charge rate is limited to avoid excessive load on the power supply, and it may take several minutes for the capacitor to reach full charge. Once the capacitor reaches near full charge the CHARGING LED will dim and extinguish, and the green “READY” LED will light up. At this point the TIS-1250 is ready to provide backup power.

The computer can remain connected and will receive full supply voltage throughout the charging sequence.

The green READY LED will remain illuminated even after the output voltage drops below the computer shut-down voltage.

Performance

The plots below show the TIS-1250 tested with a 19V input and a 5 Ohm resistive load (about 3.8 Amp load.). This is about the maximum current drawn by the NUC-style computers typically used in the wsprdaemon system. In most configurations the current will be significantly less. Recent measurements with the Beelink 5825U computer plus the attached USB-powered RX-888 show an average power consumption of about 20 Watts, although the peak load will be greater than this.

These plots show the TIS-1250 output voltage at input power disconnection, with the initial drop and the slope as the internal supercap discharges. The output voltage eventually drops to 12V (below which the NUC may shut down) is 2.58 seconds. This holdover time greatly exceeds the switching time of even a slow-switching UPS, guaranteeing glitchless backup power.





The initial voltage drop is due to the Effective Series Resistance of the SC1 supercap (about 0.74 Ohms), and to a much lesser extent the resistance of the R5 PolySwitch (0.2 Ohms @ 4A), and the Q1 on-resistance (about 0.025 Ohms). This drop is a function of current, so with lighter loads the drop will be less and of course the backup time will be longer..